



PFD DIRECT DRIVE PANEL FAN

Daltec's PFD fan is right at home in all OEM or industrial settings. Standard equipment includes an adjustable pitch impeller, which allows for exact performance matching without the need for belts and pulleys. The DPF fan impeller incorporates the most efficient combination of high air volume, low power consumption and low noise. A heavy gauge steel housing and performance enhancing deep drawn venturi are also standard fare. For appearance and protection we coat every unit with a durable powder coat paint.

Daltec ... building fans to stand the test of time.

Design Features

- Cast aluminum or GRP construction
- Standard sizes 10" to 72" diameter
- 2 to 16 blade/hub combinations
- Adjustable pitch airfoil impeller
- Excellent sound performance
- 300 – 100,000 CFM
- Maintenance free

Optional Items

- ATEX motors
- Belt drive fans
- Custom designs
- Choice of colors
- Oversized & hinged panels
- AMCA spark resistant construction
- Mounting boots, dampers, filter boxes
- Motor side and/or propeller side guard
- TEFC, explosion proof, mill & chem motors
- Single phase, three phase, 50 HZ & 60 HZ
- Stainless steel, aluminum or galvanized construction



PFD DIRECT DRIVE PANEL FAN

Durable, Reliable and Rugged ... Daltec Fans built to last

(4) #1/2 HOLES FOR MOUNTING

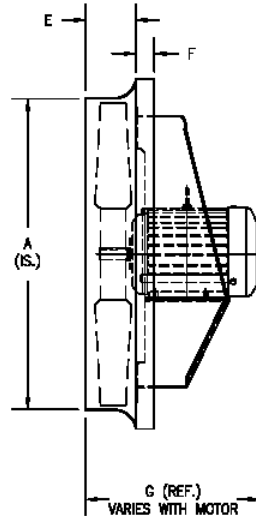
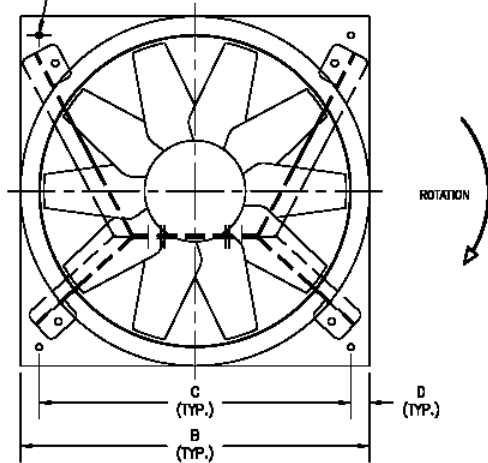

DIRECTION OF AIR FLOW

Dimensions (inches)						
Model	A	B	C	E	F	T
PFD 12	12.5	16	13	2.5	1.5	16 ga.
PFD 18	18.75	22	19	2.5	1.5	14 ga.
PFD 21	21.75	25	22	4	1.5	14 ga.
PFD 24	24.875	28	25	4	1.5	14 ga.
PFD 27	27.875	32	29	4	1.5	14 ga.
PFD 30	31	36	33.25	4	2	14 ga.
PFD 36	36.875	42	39.25	4	2	14 ga.
PFD 42	42.875	48	42.25	4.75	3	14 ga.
PFD 48	48.875	54	51.25	5	3	14 ga.
PFD 54	55	60	N/A	5.5	4	12 ga.

Dimensions are preliminary and are not to be used for construction. Please contact Daltec (888) 532-5832 for exact dimensional details.

Optional Items and Accessories

- Mounting Boot
- Automatic (Gravity) Damper
- Motorized Damper
- Propeller Side OSHA Guard
- Motor Side OSHA Guard
- High Temperature Designs
- Filter Cabinet
- Weather Hood
- Reversible Designs
- Plastic and Aluminum Impellers
- Aluminum Housings
- Heavy Duty Box Designs
- Custom Housings

Also Available From Daltec

Custom GPI Pressure Blowers & Fans



Industrial Roof Exhaust Fans



Heavy Duty Exhaust Fans & Blowers



Mixed Flow Fans & Impellers



For complete performance ratings and/or quotation, please contact your local Daltec sales representative or call (888) 5DALTEC (532-5832) for assistance



Canada:
Daltec Industries Ltd.
Guelph, Ontario, N1E 5V5
Tel: (519) 837-1921
Toll Free: (888) 532-5832
faninfo@daltecfans.com
www.daltecfans.com

United States:
Daltec Industries Ltd.
Maple Grove, Minnesota, 55311
Toll Free: (888) 5Daltec
(888) 532-5832
wdimarco@daltecfans.com
www.daltecfans.com

